

Grizzly *Industrial, Inc.*®

MODEL G0529 OSCILLATING SPINDLE & 12" DISC SANDER OWNER'S MANUAL



COPYRIGHT © SEPTEMBER, 2003 BY GRIZZLY INDUSTRIAL, INC. REVISED JUNE, 2014 (ST)
**WARNING: NO PORTION OF THIS MANUAL MAY BE REPRODUCED IN ANY SHAPE
OR FORM WITHOUT THE WRITTEN APPROVAL OF GRIZZLY INDUSTRIAL, INC.**
#JT5422 PRINTED IN TAIWAN



WARNING!

This manual provides critical safety instructions on the proper setup, operation, maintenance, and service of this machine/tool. Save this document, refer to it often, and use it to instruct other operators.

Failure to read, understand and follow the instructions in this manual may result in fire or serious personal injury—including amputation, electrocution, or death.

The owner of this machine/tool is solely responsible for its safe use. This responsibility includes but is not limited to proper installation in a safe environment, personnel training and usage authorization, proper inspection and maintenance, manual availability and comprehension, application of safety devices, cutting/sanding/grinding tool integrity, and the usage of personal protective equipment.

The manufacturer will not be held liable for injury or property damage from negligence, improper training, machine modifications or misuse.



WARNING!

Some dust created by power sanding, sawing, grinding, drilling, and other construction activities contains chemicals known to the State of California to cause cancer, birth defects or other reproductive harm. Some examples of these chemicals are:

- **Lead from lead-based paints.**
- **Crystalline silica from bricks, cement and other masonry products.**
- **Arsenic and chromium from chemically-treated lumber.**

Your risk from these exposures varies, depending on how often you do this type of work. To reduce your exposure to these chemicals: Work in a well ventilated area, and work with approved safety equipment, such as those dust masks that are specially designed to filter out microscopic particles.

Table of Contents

SECTION 1: SAFETY	2	SECTION 6: OPERATIONS	17
Safety Instructions for Machinery	2	General	17
SECTION 2: INTRODUCTION	5	Power Switch	17
Foreword.....	5	Spindle Sanding.....	18
Contact Info.....	5	Disc Sanding.....	19
SECTION 3: CIRCUIT REQUIREMENTS	6	Miter Sanding.....	19
110V Operation.....	6	SECTION 7: MAINTENANCE	20
SECTION 4: MACHINE FEATURES	7	Maintenance Safety	20
SECTION 5: SET UP	8	Schedule	20
Unpacking	8	Machine Data Sheet	22
Parts Inventory.....	8	Wiring Diagram	24
Hardware Recognition Chart	9	Frame Breakdown.....	25
Clean Up.....	10	Frame Parts List	26
Site Considerations.....	10	Cabinet Breakdown.....	28
Beginning Assembly	11	Troubleshooting	29
Cabinet Assembly	11	WARRANTY AND RETURNS	33
Mounting Sander.....	12		
Installing Spindle.....	12		
Table Inserts	13		
Squaring Table.....	13		
Squaring Disc Sander	14		
Sanding Disc.....	15		
Installation.....	15		
Aligning Table	15		
Miter Gauge	16		
Dust Collection.....	16		

SECTION 1: SAFETY

WARNING

For Your Own Safety, Read Instruction Manual Before Operating this Machine

The purpose of safety symbols is to attract your attention to possible hazardous conditions. This manual uses a series of symbols and signal words intended to convey the level of importance of the safety messages. The progression of symbols is described below. Remember that safety messages by themselves do not eliminate danger and are not a substitute for proper accident prevention measures.



Indicates an imminently hazardous situation which, if not avoided, **WILL** result in death or serious injury.



Indicates a potentially hazardous situation which, if not avoided, **COULD** result in death or serious injury.



Indicates a potentially hazardous situation which, if not avoided, **MAY** result in minor or moderate injury. It may also be used to alert against unsafe practices.

NOTICE

This symbol is used to alert the user to useful information about proper operation of the machine.

WARNING

Safety Instructions for Machinery

OWNER'S MANUAL. Read and understand this owner's manual **BEFORE** using machine. Untrained users can be seriously hurt.

EYE PROTECTION. Always wear ANSI-approved safety glasses or a face shield when operating or observing machinery. to reduce the risk of eye injury or blindness from flying particles Everyday eyeglasses are not approved safety glasses.

HAZARDOUS DUST. Dust created while using machinery may cause cancer, birth defects, or long-term respiratory damage. Be aware of dust hazards associated with each workpiece material, and always wear a NIOSH-approved respirator to reduce your risk.

WEARING PROPER APPAREL. Do not wear clothing, apparel, or jewelry that can become entangled in moving parts. Always tie back or cover long hair. Wear non-slip footwear to avoid accidental slips which could cause a loss of workpiece control.

HEARING PROTECTION. Always wear hearing protection when operating or observing loud machinery. Extended exposure to this noise without hearing protection can cause permanent hearing loss.

MENTAL ALERTNESS. Be mentally alert when running machinery. Never operate under the influence of drugs or alcohol, when tired, or when distracted.

WARNING

Safety Instructions for Machinery

DISCONNECTING POWER SUPPLY. Always disconnect machine from power supply before servicing, adjusting, or changing cutting tools (bits, blades, cutters, etc.). Make sure switch is in OFF position before reconnecting to avoid an unexpected or unintentional start.

INTENDED USE. Only use the machine for its intended purpose and only use recommended accessories. Never stand on machine, modify it for an alternative use, or outfit it with non-approved accessories.

STABLE MACHINE. Unexpected movement during operations greatly increases the risk of injury and loss of control. Verify machines are stable/secure and mobile bases (if used) are locked before starting.

FORCING MACHINERY. Do not force machine. It will do the job safer and better at the rate for which it was designed.

GUARDS & COVERS. Guards and covers can protect you from accidental contact with moving parts or flying debris. Make sure they are properly installed, undamaged, and working correctly before using machine.

REMOVING TOOLS. Never leave adjustment tools, chuck keys, wrenches, etc. in or on machine—especially near moving parts. Verify removal before starting!

AWKWARD POSITIONS. Keep proper footing and balance at all times when operating machine. Do not overreach! Avoid awkward hand positions that make workpiece control difficult or increase the risk of accidental injury.

DANGEROUS ENVIRONMENTS. Do not use machinery in wet locations, cluttered areas, around flammables, or in poorly-lit areas. Keep work area clean, dry, and well lighted to minimize risk of injury.

APPROVED OPERATION. Untrained operators can be seriously hurt by machinery. Only allow trained or properly supervised people to use machine. When machine is not being used, disconnect power, remove switch keys, or lock-out machine to prevent unauthorized use—especially around children. Make workshop kid proof!

CHILDREN & BYSTANDERS. Keep children and bystanders a safe distance away from work area. Stop using machine if children or bystanders become a distraction.

FEED DIRECTION. Unless otherwise noted, feed work against the rotation of blades or cutters. Feeding in the same direction of rotation may pull your hand into the cut.

SECURING WORKPIECE. When required, use clamps or vises to secure workpiece. A secured workpiece protects hands and frees both of them to operate the machine.

UNATTENDED OPERATION. Never leave machine running while unattended. Turn machine **OFF** and ensure all moving parts completely stop before walking away.

MAINTENANCE & INSPECTION. A machine that is not properly maintained may operate unpredictably. Follow all maintenance instructions and lubrication schedules to keep machine in good working condition. Regularly inspect machine for loose bolts, alignment of critical parts, binding, or any other conditions that may affect safe operation. Always repair or replace damaged or mis-adjusted parts before operating machine.

EXPERIENCING DIFFICULTIES. If at any time you are experiencing difficulties performing the intended operation, stop using the machine! Contact our Technical Support Department at (570) 546-9663.

⚠️ WARNING

Additional Safety Instructions For Oscillating Spindle & Disc Sander

- **READ THIS MANUAL.** This manual contains proper operating instructions for this machine.
- **DO NOT** jam the workpiece against the sanding surfaces. Firmly grasp the workpiece in both hands and ease it against the spindle/disc using light pressure.
- **DO NOT** wear loose clothing while operating this machine. Roll up or button sleeves at the cuff.
- **DO NOT** place hands near, or in contact with, sanding surfaces during operation.
- **GRIP THE WORKPIECE WITH BOTH HANDS.**
- **PERFORM** machine inspections and maintenance service promptly when called for.
- **NEVER** leave the machine running unattended.
- **REPLACE** sanding discs and sleeves when they become worn.
- **NEVER** sand more than one piece of stock at a time.
- **ALWAYS** inspect board stock for nails, staples, knots, and other imperfections that could be dislodged and thrown from the machine during sanding operations.
- **NEVER** operate the sander without an adequate dust collection system in place and running.
- **NEVER** sand tapered or pointed stock with the point facing the feed direction.
- **DISCONNECT THE MACHINE FROM THE POWER SOURCE** before changing the sanding disc or sleeve.
- **TEST RUN THE MACHINE** before starting any work.

⚠️ CAUTION

No list of safety guidelines can be complete. Every shop environment is different. Always consider safety first, as it applies to your individual working conditions. Use this and other machinery with caution and respect. Failure to follow guidelines could result in serious personal injury, damage to equipment or poor work results.

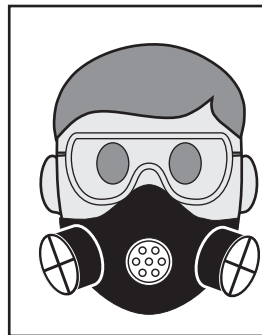

⚠️ CAUTION

Always wear a respirator when operating the Model G0529. Using this machine produces sawdust which may cause allergic reactions or respiratory problems.

SECTION 2: INTRODUCTION

Foreword

We are proud to offer the Model G0529 Oscillating Spindle & Disc Sander. This machine is part of a growing Grizzly family of fine woodworking machinery. When used according to the guidelines set forth in this manual, you can expect years of trouble-free, enjoyable operation and proof of Grizzly's commitment to customer satisfaction.

The specifications, drawings, and photographs illustrated in this manual represent the Model G0529 when the manual was prepared. However, owing to Grizzly's policy of continuous improvement, changes may be made at any time with no obligation on the part of Grizzly.

For your convenience, we always keep current Grizzly manuals available on our website at **www.grizzly.com**. Any updates to your machine will be reflected in these manuals as soon as they are complete. Visit our site often to check for the latest updates to this manual!



Contact Info

We stand behind our machines. If you have any service questions or parts requests, please call or write us at the location listed below.

Grizzly Industrial, Inc.
1203 Lycoming Mall Circle
Muncy, PA 17756
Phone: (570) 546-9663
Fax: (800) 438-5901
E-Mail: techsupport@grizzly.com
Web Site: <http://www.grizzly.com>

If you have any comments regarding this manual, please write to us at the address below:

Grizzly Industrial, Inc.
c/o Technical Documentation Manager
P.O. Box 2069
Bellingham, WA 98227-2069
Email: manuals@grizzly.com



SECTION 3: CIRCUIT REQUIREMENTS

110V Operation

⚠️ WARNING

Serious personal injury could occur if you connect the machine to power before completing the setup process. **DO NOT** connect the machine to the power until instructed later in this manual.



⚠️ WARNING

Electrocution or fire could result if machine is not grounded and installed in compliance with electrical codes. Compliance **MUST** be verified by a qualified electrician!

Full Load Amperage Draw

This machine draws the following amps under maximum load:

Amp Draw..... 10 Amps

Power Supply Circuit Requirements

You **MUST** connect your machine to a grounded circuit that is rated for the amperage given below. Never replace a circuit breaker on an existing circuit with one of higher amperage without consulting a qualified electrician to ensure compliance with wiring codes. **If you are unsure about the wiring codes in your area or you plan to connect your machine to a shared circuit, consult a qualified electrician.**

Minimum Circuit Size..... 15 Amps

Power Connection Device

The Model G0529 comes with a 5-15 plug, similar to **Figure 1**, to connect the machine to power.

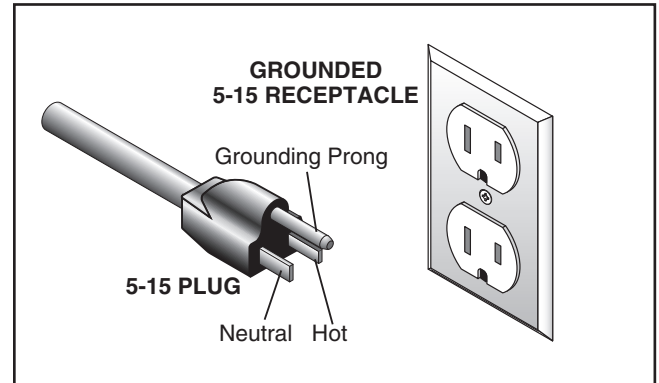
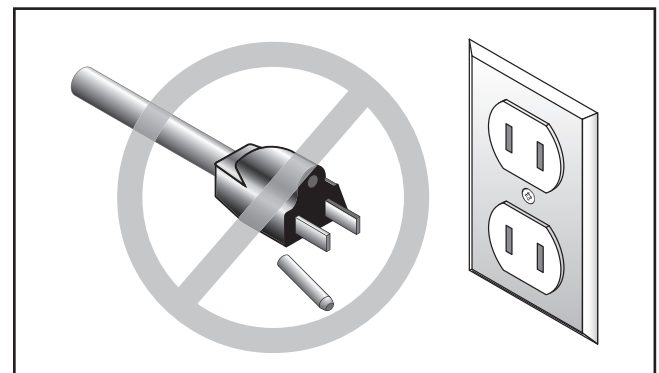

Figure 1. Typical 5-15 plug and receptacle.



⚠️ CAUTION

This machine **MUST** have a ground prong in the plug to help ensure that it is grounded. **DO NOT** remove ground prong from plug to fit into a two-pronged outlet! **If the plug will not fit the outlet, have the proper outlet installed by a qualified electrician.**

Extension Cords

We do not recommend using extension cords, but if you find it absolutely necessary:

- Use at least a 14 gauge cord that does not exceed 50 feet in length!
- The extension cord must have a ground wire and plug pin.
- A qualified electrician **MUST** size cords over 50 feet long to prevent motor damage.

SECTION 4: MACHINE FEATURES

An important part of safety is knowing your machine and its components. Take the time to familiarize yourself with the features of your new G0529 Oscillating Spindle & 12" Disc Sander. They will be frequently mentioned throughout the instructions in this manual.

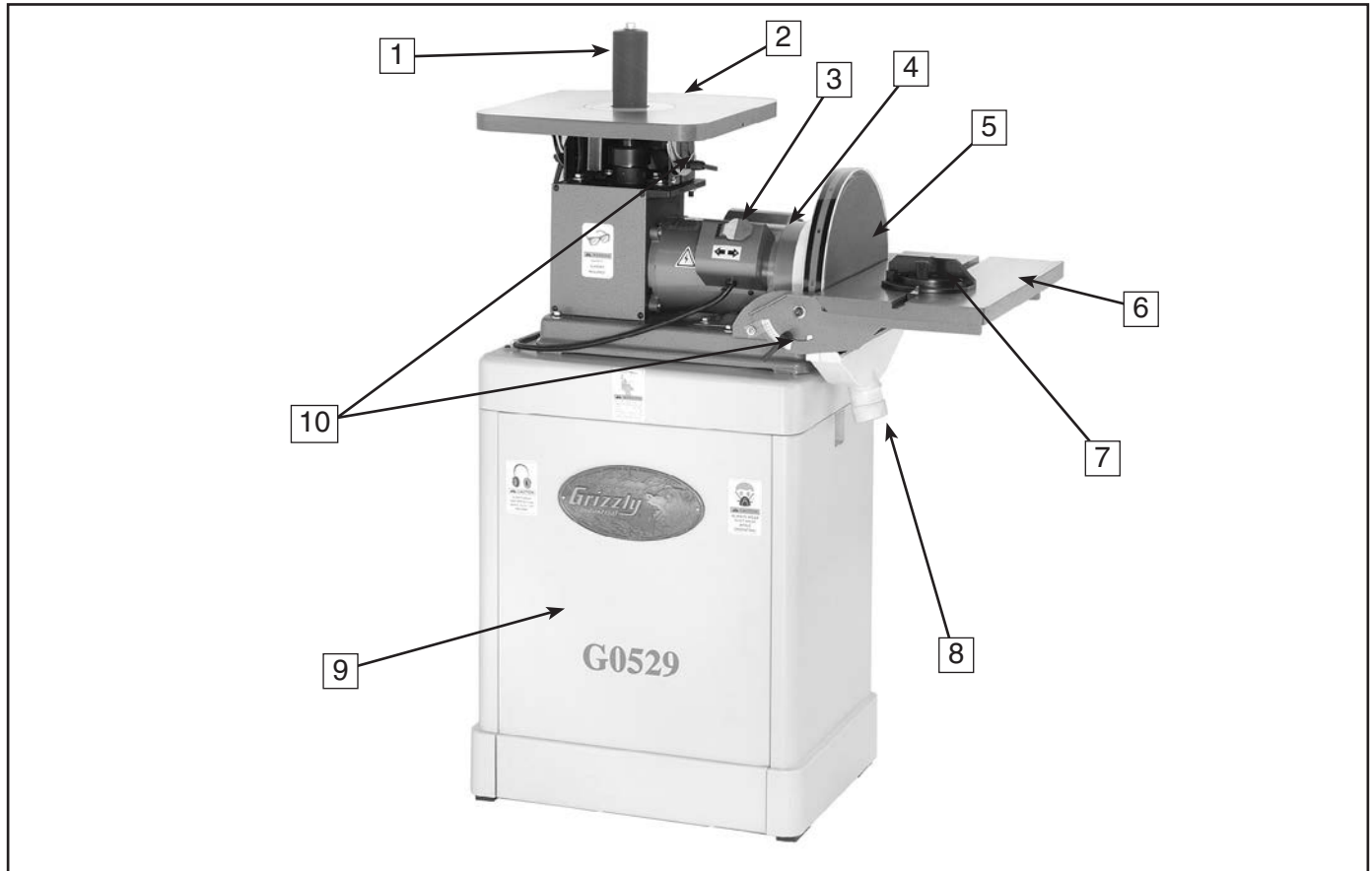



Figure 2. Machine features.

1. Sanding Spindle
2. Cast Iron Spindle Sanding Table
3. Power Switch
4. Motor
5. Sanding Disc
6. Cast Iron Disc Sanding Table
7. Miter Gauge
8. Dust Ports (Spindle Port Not Shown)
9. Cabinet
10. Graduated Scales

SECTION 5: SET UP

Unpacking

The Model G0529 Oscillating Spindle & 12" Disc Sander was carefully packed at the factory. If you discover the machine is damaged after you have signed for delivery, and the truck and driver are gone, you will need to file a freight claim with the carrier. Save the containers and all packing materials for possible inspection by the carrier or its agent. Without the packing materials, filing a freight claim can be difficult. If you need assistance determining whether you need to file a freight claim, or with the procedure to file one, please contact our Customer Service.



⚠️ WARNING

The Model G0529 is a heavy machine. Personal injury could occur if the machine is moved without additional assistance. Seek help when moving or lifting the machine.



⚠️ CAUTION

Sharp edges on metal parts may cause personal injury. Examine the edges of all metal parts before handling.

When you are completely satisfied with the condition of your shipment, you should inventory its parts.



Parts Inventory

DESCRIPTION	Qty
A. Sander unit	1
B. Left and Right Side Panels.	2
C. Front and Rear Panels	2
D. Miter Gauge Assembly	1
E. Spindle Assemblies	
• 2"	1
• 1½"	1
• 5⁄8"	1
• ¼"	1
F. Table Inserts	
• Oval Table Insert 2"	1
• Table Insert 2"	1
• Oval Table Insert ¾"	1
• Table Insert ¾"	1
G. Rubber Floor Pads	
• Flat Head Screws 5⁄16"-18 x ¾"	4
• Washers 5⁄16"	4
• Nuts 5⁄16"	4
H. Wrench Hardware Bag	
• Open End Wrench 17mm	2
• Open End Wrench 12mm	1
I. Hardware Bag	
• Hex Bolts 5⁄16"-18 x ¾"	8
• Hex Nuts 5⁄16"-18.	10
• Lock Washers 5⁄16"	10
• Washers 5⁄16"	18
• Hex Bolts 5⁄16"-18 x 1¼"	2
• Hex Key 6mm.	1

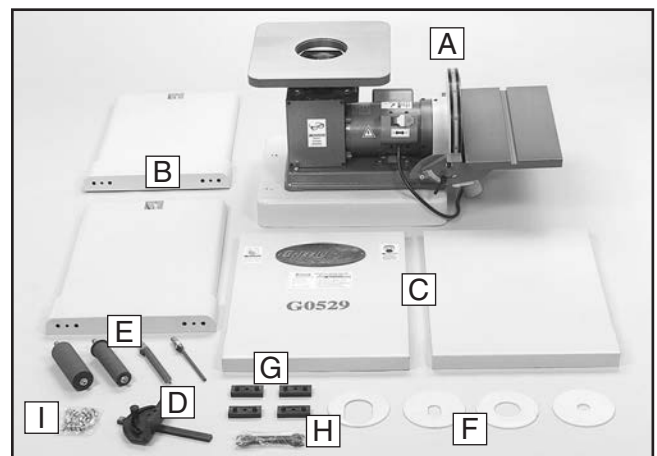

Figure 3. G0529 inventory.



Hardware Recognition Chart

USE THIS CHART TO MATCH UP HARDWARE DURING THE ASSEMBLY PROCESS.

MEASURE BOLT DIAMETER BY PLACING INSIDE CIRCLE

- #10
- 1/4"
- 5/16"
- 3/8"
- 7/16"
- 1/2"

- 4mm
- 6mm
- 8mm
- 10mm
- 12mm
- 16mm

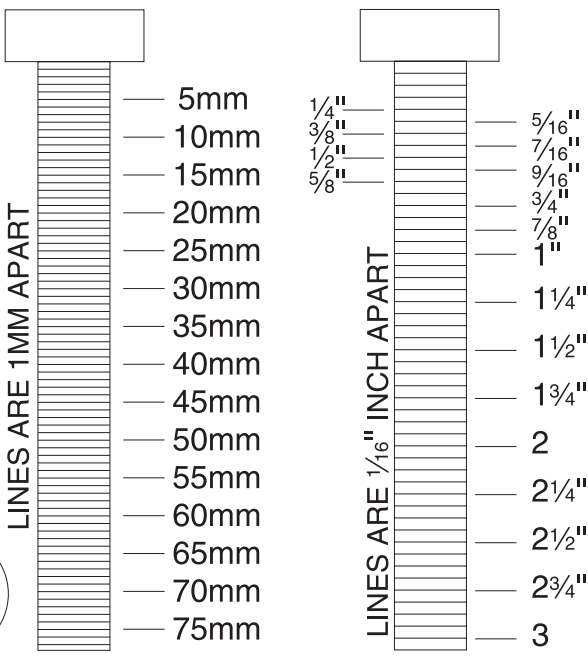
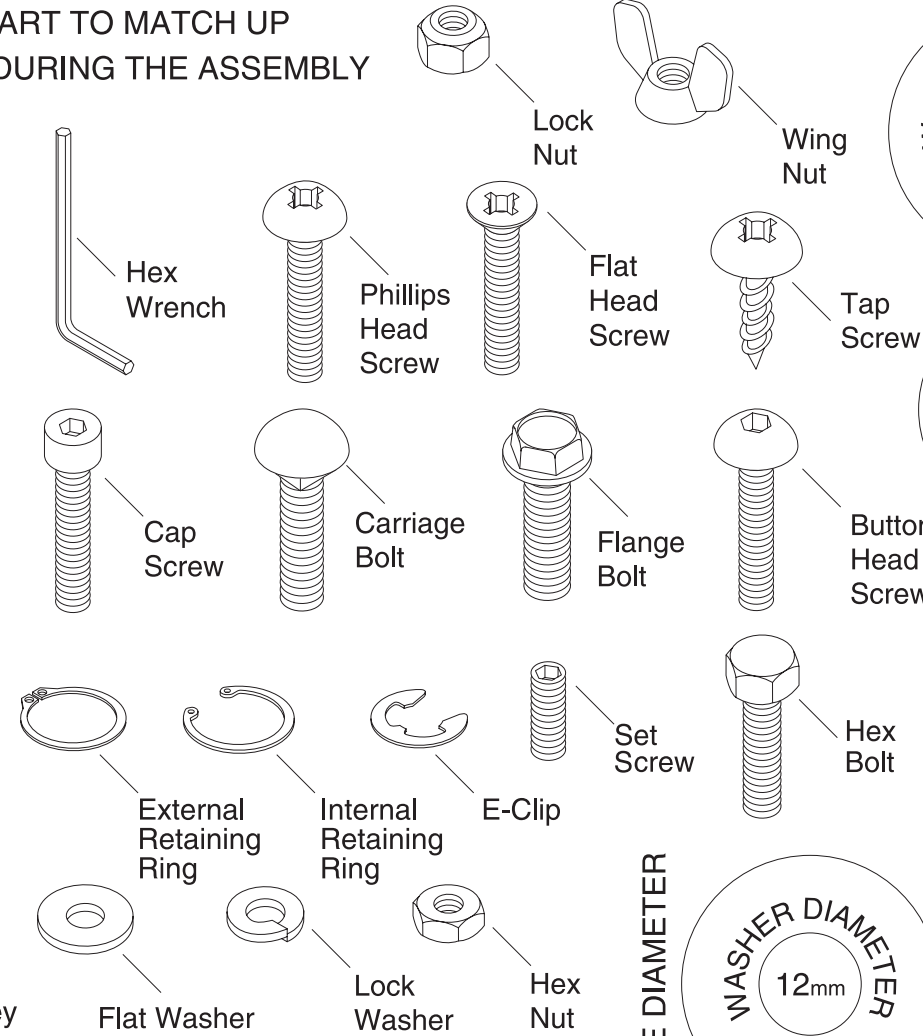

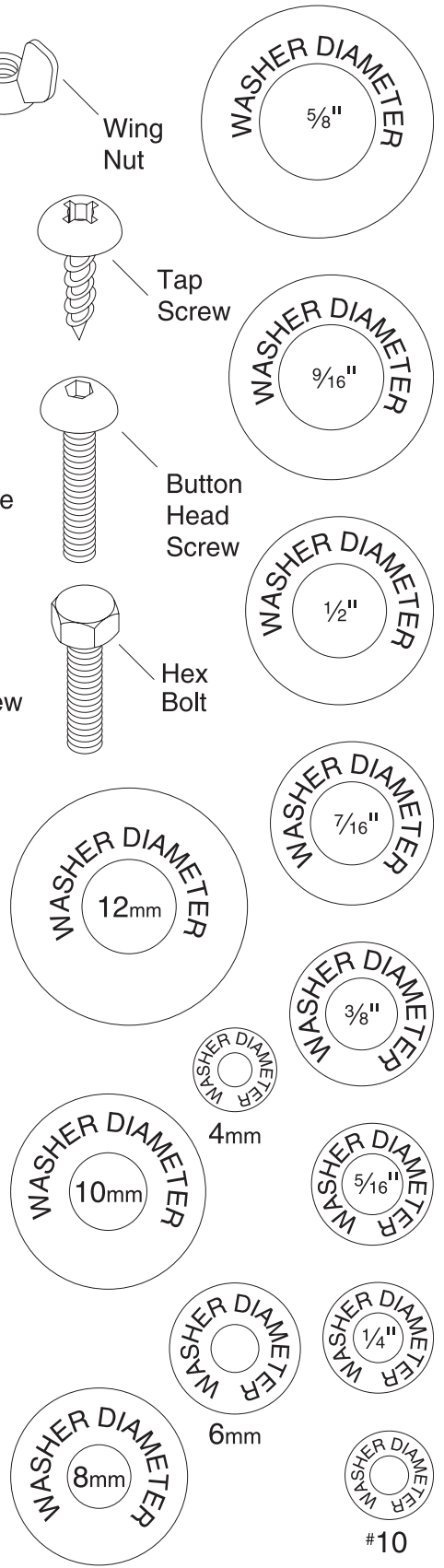

WASHERS ARE MEASURED BY THE INSIDE DIAMETER



Clean Up

The unpainted surfaces are coated with a waxy oil to protect them from corrosion during shipment. Remove this protective coating with a solvent cleaner or citrus-based degreaser such as Grizzly's G7895 Degreaser. To clean thoroughly, some parts may need to be removed. **For optimum performance from your machine, make sure you clean all moving parts or sliding contact surfaces that are coated.** Avoid chlorine-based solvents as they may damage painted surfaces should they come in contact.

	<p>⚠️ WARNING</p> <p>Gasoline and petroleum products have low flash points and could explode if used to clean machinery. DO NOT use gasoline or petroleum products to clean the machinery.</p>
---	--

	<p>⚠️ WARNING</p> <p>Smoking near solvents could ignite an explosion or fire and cause serious injury. DO NOT smoke while using solvents.</p>
---	---

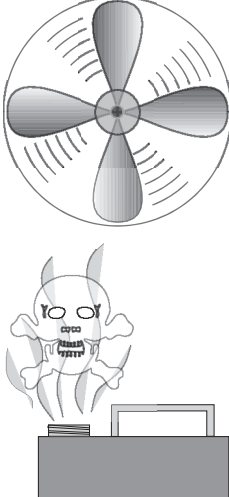
	<p>⚠️ WARNING</p> <p>Lack of ventilation while using solvents could cause serious personal health risks, fire, or environmental hazards. Always work in a well ventilated area to prevent the accumulation of dangerous fumes. Supply the work area with a constant source of fresh air.</p>
---	---



Site Considerations

Weight Load

The Model G0529 weighs 166 lbs. and has a 21¹/₄" X 16¹/₂" footprint. Most shop floors should be sufficient to carry the weight of the machine. Reinforce the floor if you question its ability to support the weight.

Working Clearance

Working clearances can be thought of as the distances between machines and obstacles that allow safe operation of every machine without limitation. Consider existing and anticipated machine needs, size of material to be processed through each machine, and space for auxiliary stands or work tables. Also consider the relative position of each machine to one another for efficient material handling.

Lighting And Outlets Lighting should be bright enough to eliminate shadow and prevent eye strain. Electrical circuits should be dedicated or large enough to handle the amperage draw. Outlets should be located near each machine so power or extension cords are clear of high-traffic areas. Observe local electrical codes for proper installation of new lighting, outlets, or circuits.

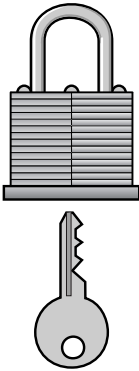
	<p>⚠️ WARNING</p> <p>Unsupervised children and visitors inside your shop could receive serious personal injury. Ensure child and visitor safety by keeping all entrances to the shop locked at all times. DO NOT allow unsupervised children or visitors in the shop at any time.</p>
--	---





Beginning Assembly

This section will cover the basic assembly and adjustment instructions needed to begin operation. Complete the assembly in the order provided in this manual and then read the remaining portion of the manual before attempting any type of operation.

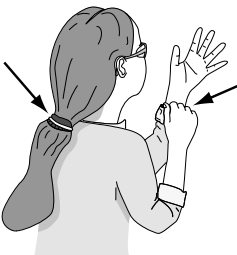
Your safety is important! Please follow the warnings below during this entire section:

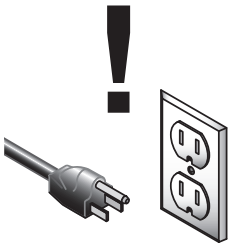
	<p>! WARNING</p> <p>Loose hair and clothing could get caught in machinery and cause serious personal injury. Keep loose clothing rolled up and long hair tied up and away from machinery.</p>
---	--

	<p>! WARNING</p> <p>Serious personal injury could occur if you connect your machine to the power source before you have completed the assembly process. DO NOT connect the machine to the power source until instructed to do so.</p>
---	--

	<p>! CAUTION</p> <p>Sharp edges on metal parts may cause personal injury. Examine the edges of all metal parts before handling.</p>
---	--



Cabinet Assembly

The Model G0529 Sander mounts on a sturdy cabinet stand.

To assemble the cabinet stand:

1. Connect all four panels together with the $\frac{5}{16}$ " -18 x $\frac{3}{4}$ " hex bolts, lock washers, washers and hex nuts (**Figure 4**).



Figure 4. Assembled panels.

2. Using the $\frac{5}{16}$ " flat head screws, $\frac{5}{16}$ " washers and nuts, install the four rubber feet as shown in **Figure 5**.



Figure 5. Installing rubber feet.



Mounting Sander

When the cabinet has been completed, it is time to place the sander unit on top of the cabinet stand.

To mount the sander to the top of the cabinet stand:

1. With the help of an assistant, place the sander on the cabinet stand.

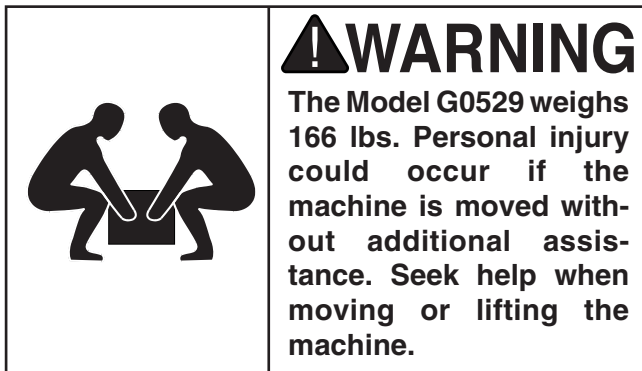

2. Align the holes on the rim of the cabinet sides with the threaded holes in the rim of the sander.
3. Secure the cabinet and the sander together with the $\frac{5}{16}$ "-18 x $1\frac{1}{4}$ " hex bolts, $\frac{5}{16}$ " lock washers, and $\frac{5}{16}$ " flat washers combination as shown in **Figure 6**.



Figure 6. Cabinet hole location.



Installing Spindle

To install the spindle onto the sander:

1. **Disconnect the machine from the power supply.**

2. Select the proper diameter of spindle sleeve.

The Model G5029 comes with the following four sizes of spindle sleeves:

- $\frac{1}{4}$ "
- $\frac{5}{8}$ "
- $1\frac{1}{2}$ "
- 2"

3. Make sure the tapered end of the spindle sleeve is clean before installing it into the sander spindle.

4. Use the supplied open end wrenches to secure the spindle as shown in **Figure 7**. Note—*Do not over tighten the spindle sleeve, it could make removal difficult.*

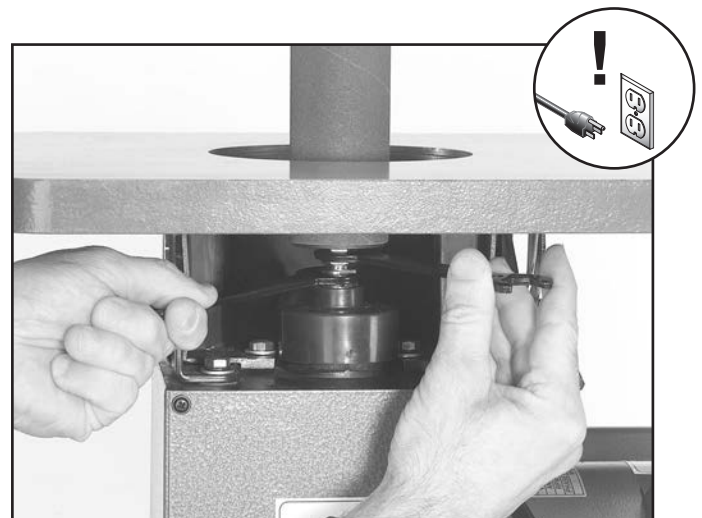

Figure 7. Installing spindle.



Table Inserts

The table inserts minimize the gap between the working surface edge and the spindle. It is important to use the proper table insert according to the diameter spindle you are using.

The Model G5029 comes with the following four table inserts:

- 2"
- 1"
- 2" elliptical
- 1" elliptical

Select the table insert that comes closest the spindle sleeve diameter without touching it. The elliptical inserts are used when sanding with the table tilted.

Place the table insert into the table hole as shown in **Figure 8**.

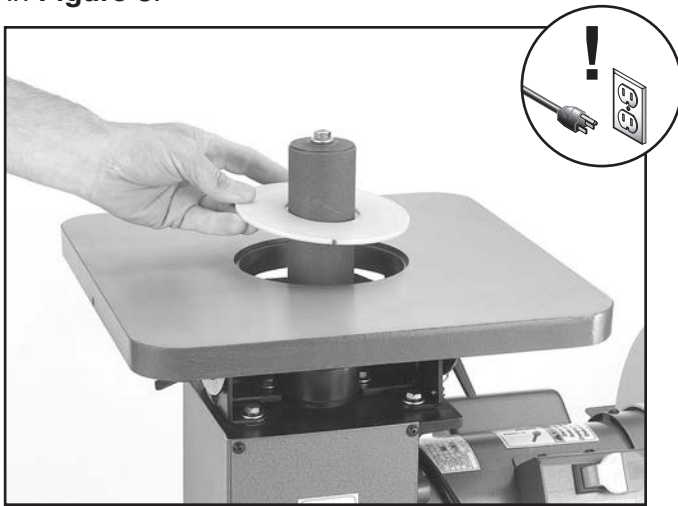

Figure 8. Installing table inserts.



Squaring Table

To square the sanding tables:

1. Disconnect the machine from the power supply.
2. Set the table at 90° as shown in **Figure 9**.

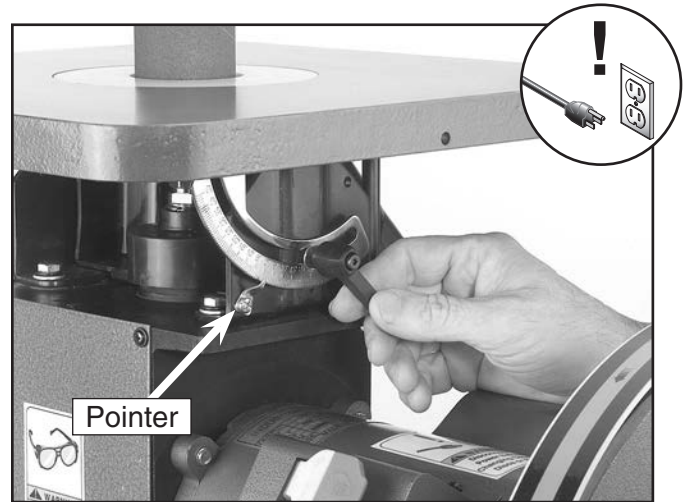

Figure 9. Setting the table scale at 90°.

3. Place a machinist square on the table and against the sanding spindle to verify the table is 90° from the edge of the sanding sleeve as shown in **Figure 10**.
4. Adjust the pointer to 90°.

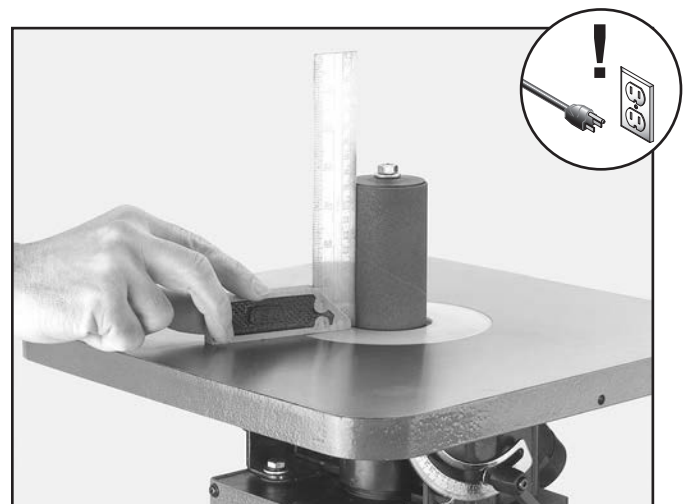

Figure 10. Squaring the table and spindle.

5. If the table is not 90° from the spindle, adjust the table stop bolt to allow the table to move more as shown in **Figure 11**.

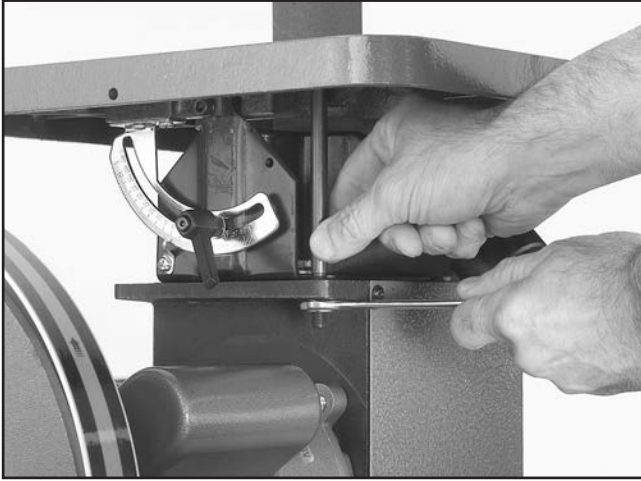

Figure 11. Squaring the sanding table.

6. Tighten the table stop bolt against the underside of the table when the table is set at 90°.



Squaring Disc Sander

The sanding tables for the spindle sander and the disc sander have tilting capabilities from 0° to 45°.

To tilt the sanding table:

1. Disconnect the machine from the power supply.
2. Using a machinist square, set one edge on the table surface and the other against the face of the sanding disc as shown in **Figure 12**. Note—*This can be done with the sandpaper installed, although it is somewhat easier to measure if the disc does not have the sandpaper disc installed.*

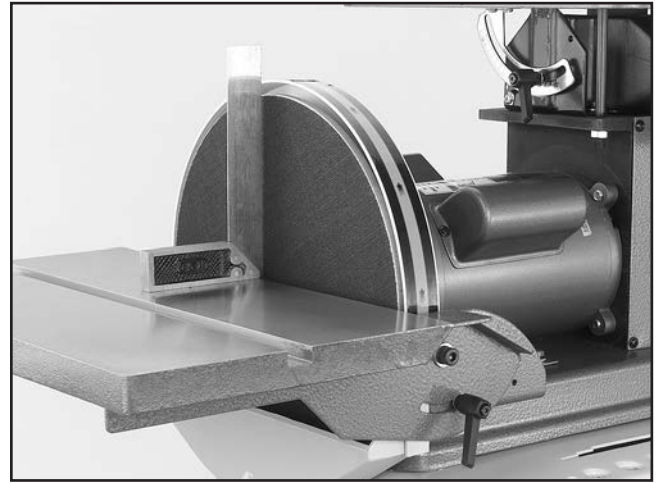

Figure 12. Squaring the disc sanding table.

3. Loosen the lock lever and adjust the table angle until it is perfectly perpendicular and flush with both edges of the machinist square.
4. Tighten the lock lever while holding the table perpendicular.
5. Adjust the scale pointer to read 0° when the table has been properly adjusted.



Sanding Disc Installation

The disc sander requires 12" PSA (pressure sensitive adhesive) sanding discs.

To install a new sanding disc on the 12" disc sanding surface:

1. Disconnect the machine from the power supply.
2. Remove the disc sanding table.
3. Remove the old sanding disc.
4. Install the new sanding disc as shown in **Figure 13**.

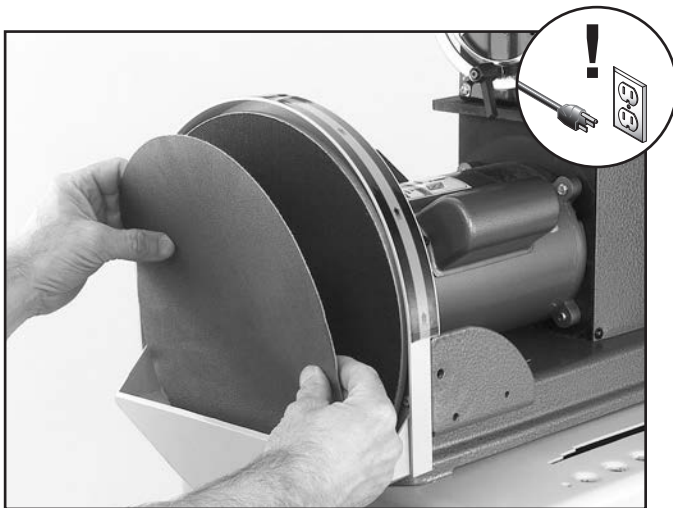

Figure 13. Installing PSA sanding disc.



Aligning Table

The table must be spaced evenly away from the face of the sanding disc so that the sandpaper does not rub against the table.

To align the table:

1. Loosen the bolts that secure the table to the table support bracket.
2. Align the table so that there is a $\frac{1}{16}$ " gap between the 12" disc and the table.
3. Tighten the bolts loosened in **Step 1**.
4. Spin the disc by hand to check if the sandpaper is touching the table. Note—*DO NOT turn the disc sander on at this point.*
5. Repeat **Steps 1-3** if the sandpaper touches table at any point in the rotation.



Miter Gauge

The miter gauge needs to be adjusted perpendicular to the face of the wheel when it is mounted in the table slot.

To adjust miter gauge:

1. Use a machinist square with one edge against the face of the miter gauge and the other against the disc face as shown in **Figure 14**.

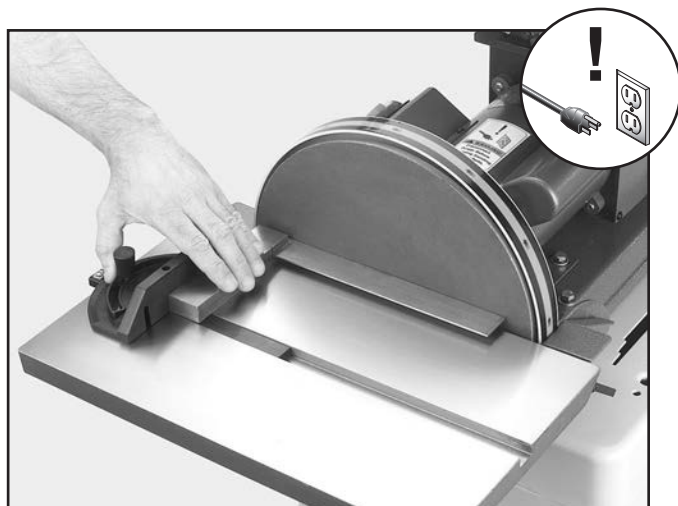

Figure 14. Squaring miter gauge to disc.

2. Loosen the lock knob on the miter gauge to adjust it flush with the edge of the square.
3. Tighten the lock knob, and verify the setting. *Note—Sometimes the tightening procedure can affect the adjustment.*
4. Loosen the setscrew that secures the angle pointer and adjust the pointer to the 0° mark on the scale.
5. Retighten the setscrew that secures the angle pointer.



Dust Collection

There are two 2" dust collection ports for the sander that should be connected to a dust collector. The ports are located under the sanding tables as shown in **Figure 15**.

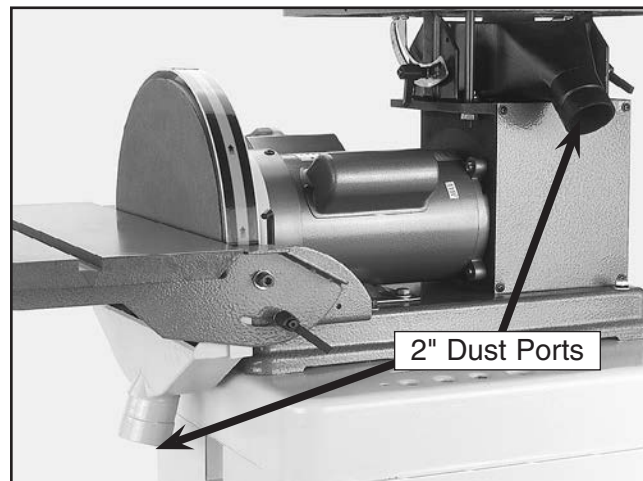

Figure 15. Dust port locations.

To connect your machine to a dust collection system:

1. Use a 2" diameter hose to connect a dust collection system to your dust ports.
2. Start the dust collection system before operating the sander.



SECTION 6: OPERATIONS

General

This section covers basic disc sanding operations. Please read the remaining portion of the manual before attempting any type of operation.

Your safety is important! Please follow the warnings below during this entire section:

⚠️WARNING

Damage to your eyes, lungs, and ears could result from failure to wear safety glasses, a respirator, and hearing protection while sanding with this machine.

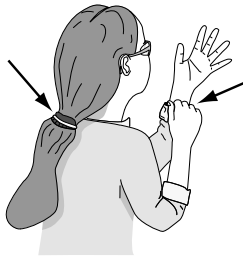

⚠️WARNING

Loose hair and clothing could get caught in machinery and cause serious personal injury. Keep loose clothing rolled up and long hair tied up and away from machinery.

⚠️WARNING

Operating this equipment has the potential to propel debris into the air which can cause eye injury. Always wear safety glasses or goggles when operating equipment. Everyday glasses or reading glasses only have impact resistant lenses, they are not safety glasses. Be certain the safety glasses you wear meet the appropriate standards of the American National Standards Institute (ANSI).

Power Switch

The Model G0529 sander is equipped with a paddle-type power switch with a safety key.

To operate the power switch:

1. Insert the safety locking key shown in **Figure 16**.



Figure 16. On/Off Switch.

2. Lift the switch to start and press to stop the motor.
3. Remove the locking key when the machine is not in use and store the key in a safe place.

⚠️WARNING

Make sure the power switch is in the OFF position before connecting the sander to the power source. Serious personal injury could occur if you connect your machine to the power source with the power switch ON.



Spindle Sanding

The oscillating spindle sander on the Model G0529 produces an extremely fine sanding finish on edges or contours. The oscillation of the spindle disperses the material contact throughout the sanding sleeve to prevent burning.

To perform spindle sanding operations:

1. Check to make sure that the table insert has been installed correctly and the spindle is secured tightly.
2. Set the angle of the table relative to the sanding sleeve. The angle can be set with the angle gauge on the spindle sander table or with a protractor for greater accuracy.

Note—The spindle sander table can be positioned from 0° to 45°, relative to the plane of the sanding surface.

3. Make sure that the appropriate spindle has been selected for the intended operation and that it is installed properly.
4. Connect the sander to a dust collection system.
5. Turn the power switch *ON* to start the spindle sander and begin sanding as shown in **Figure 17**. **DO NOT FORCE THE WORKPIECE AGAINST THE SANDING SLEEVE.**

WARNING

Never use the Model G0529 for applications other than those for which it was made. **DO NOT** overload the machine or use excess force when sanding. Severe personal injury, damage to the machine, or damage to your workpiece could occur.

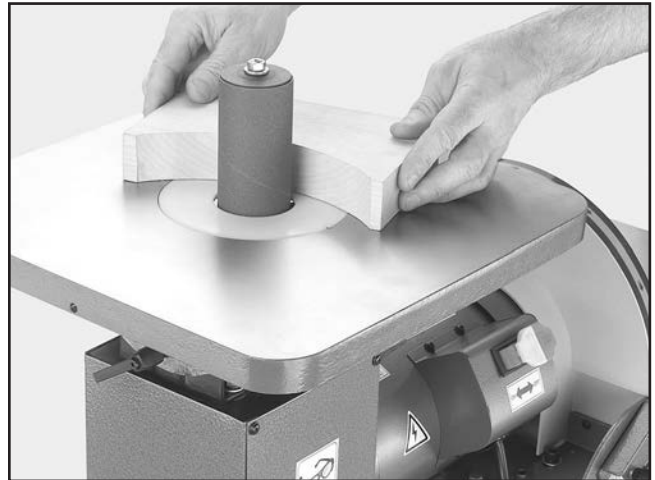

Figure 17. Spindle sanding.



Disc Sanding

To perform disc sanding operations:

1. Set the angle of the table relative to the sanding disc. The angle can be set with the angle gauge on the disc sander or with a protractor for greater accuracy.

Note—The disc table can be positioned from 0° to 45°, relative to the plane of the sanding surface.

2. Once the desired table angle has been set, move the table towards the sanding disc to decrease the gap between the table and the disc. The gap should be $\frac{1}{16}$ ".
3. To sand straight edges, firmly hold the side of workpiece against the miter gauge (set at 0°), with the other surface against the face of the disc (**Figure 18**).

Note—For sanding curves or irregular shapes, remove the miter gauge from the disc table. Always keep the workpiece on the side of the wheel that is rotating down toward the table. This will keep the workpiece from flying out of your hands from the rotational forces.



Figure 18. Disc sanding with table tilted.



Miter Sanding

The most efficient way to get a perfect miter is to cut the workpiece slightly long and sand it to the desired dimension. Miter sanding can be done easily with the miter gauge:

To perform miter sanding operations:

1. Loosen the knob on the miter gauge, adjust the angle to the desired point, and tighten the knob.
2. Slide the miter gauge into its slot and use it to hold your workpiece in position (**Figure 19**). *Note—The miter gauge can be used in either direction in the slot to achieve the proper relation of the workpiece to the disc.*



Figure 19. Disc sanding with miter.



SECTION 7: MAINTENANCE

Maintenance Safety

Your safety is important! Please follow the warnings below during this entire section:

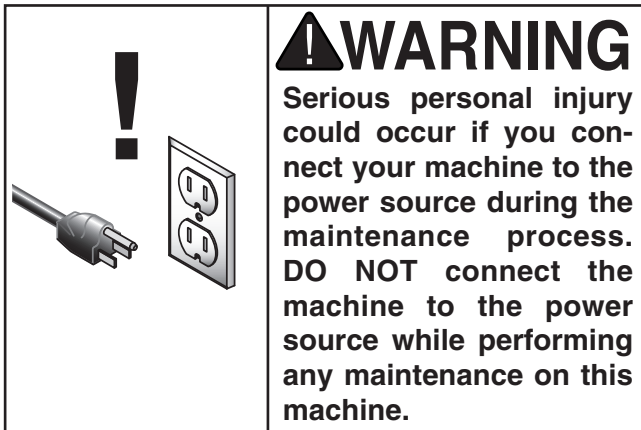

Schedule

Check for the following conditions before you use the sander:

- Loose table bolts.
- Worn or damaged sanding discs or sleeves.
- Worn or damaged wires.
- Any other condition that could hamper the safe operation of this machine.

Perform the following tasks at the scheduled time intervals:

After Each Use

- Wipe off the sawdust build-up from the table surface.
- Turn off power switch and remove the switch key.
- Check for spindle straightness.

Weekly

- Wipe a lubricant such as SLIPIT® onto the table.
- All the bearings are permanently lubricated and require no further lubrication.

Long-Term Storage

- Keep unpainted surfaces rust free with products such as Boeshield® T-9.



SECTION 8: REFERENCE INFO

Aftermarket Accessories

PRO-STICK® Abrasive Surface Cleaners
 Extend the life of your sanding discs and sleeves!

Size	Model
1½" X 1½" X 8½"	G1511
2" X 2" X 12"	G1512



Figure 20. PRO-STICK® abrasive cleaners.

Call 1-800-523-4777 To Order

A/O Sanding Sleeves

MODEL	TYPE	GRIT
H6659	¼" x 5½"	60
H6660	¼" x 5½"	80
H6661	¼" x 5½"	100
H6662	¼" x 5½"	120
H6663	¼" x 5½"	150
H6664	⅝" x 5½"	60
H6665	⅝" x 5½"	80
H6666	⅝" x 5½"	100
H6667	⅝" x 5½"	120
H6668	⅝" x 5½"	150
H6669	1½" x 5½"	60
H6670	1½" x 5½"	80
H6671	1½" x 5½"	100
H6672	1½" x 5½"	120
H6673	1½" x 5½"	150
H6674	2" x 5½"	60
H6675	2" x 5½"	80
H6676	2" x 5½"	100
H6677	2" x 5½"	120
H6678	2" x 5½"	150

12" A/O Sanding Discs

MODEL	TYPE	GRIT
G1220	12" PSA	60
G4255	12" PSA	80
G1221	12" PSA	100
G4256	12" PSA	120
G1222	12" PSA	150
G4257	12" PSA	180
G4258	12" PSA	220





MACHINE DATA SHEET

Customer Service #: (570) 546-9663 · To Order Call: (800) 523-4777 · Fax #: (800) 438-5901

MODEL G0529 OSCILLATING SPINDLE / 12" DISC SANDER

Product Dimensions:

Weight..... 166 lbs.
Width (side-to-side) x Depth (front-to-back) x Height..... 32 x 18 x 47 in.
Footprint (Length x Width)..... 21-1/4 x 16-1/2 in.

Shipping Dimensions:

Type..... Cardboard Box
Content..... Machine
Weight..... 181 lbs.
Length x Width x Height..... 34 x 20 x 21 in.
Must Ship Upright..... Yes

Electrical:

Power Requirement..... 110V, Single-Phase, 60 Hz
Prewired Voltage..... 110V
Full-Load Current Rating..... 10A
Minimum Circuit Size..... 15A
Connection Type..... Cord & Plug
Power Cord Included..... Yes
Power Cord Length..... 6 ft.
Power Cord Gauge..... 14 AWG
Plug Included..... Yes
Included Plug Type..... 5-15
Switch Type..... Paddle Safety Switch w/Removable Key

Motors:

Main

Type..... TEFC Capacitor-Start Induction
Horsepower..... 1 HP
Phase..... Single-Phase
Amps..... 10A
Speed..... 1725 RPM
Power Transfer Gear Drive
Bearings..... Sealed & Permanently Lubricated

Main Specifications:

Disc Sander Info

Disc Diameter..... 12 in.
Disc Speed..... 1725 RPM
Disc Sandpaper Backing Type..... PSA
Table Length..... 17-3/4 in.
Table Width..... 10 in.
Table Thickness..... 1 in.
Table Tilt..... Left 0, Right 45 deg.
Table-to-Floor Height..... 33 in.

Spindle Sander Info

Sanding Drum Diameters.....	1/4, 5/8, 1-1/2, 2 in.
Sanding Drum Length.....	5-1/2 in.
Spindle Speed.....	1725 RPM
Spindle Oscillation.....	60 SPM
Stroke Length.....	1 in.
Table Length.....	14-1/2 in.
Table Width.....	14-1/2 in.
Table Thickness.....	1 in.
Table-to-Floor Height.....	42 in.
Spindle Shaft Diameter.....	1/4 in.
Number of Table Inserts.....	4
Included Sanding Sleeve Grit Size.....	100
Table Tilt.....	Left 10, Right 45 deg.

Construction Materials

Base.....	Preformed Steel
Stand.....	Preformed Steel
Table.....	Precision Ground Cast Iron
Frame.....	Cast Iron
Disc.....	Computer Balanced Aluminum
Miter Gauge.....	Plastic/Steel Bar
Paint Type/Finish.....	Powder Coated

Other Related Info

Miter Gauge Slot Width.....	3/4 in.
Miter Gauge Slot Height.....	3/8 in.
Number of Dust Ports.....	2
Dust Port Size.....	2 in.
Compatible Mobile Base.....	D2057A

Other Specifications:

Country Of Origin	Taiwan
Warranty	1 Year
Approximate Assembly & Setup Time	45 Minutes
Serial Number Location	ID Label on Front of Stand
ISO 9001 Factory	Yes
CSA Certified	No

Features:

- Four Spindle Sizes
- Miter Gauge Included
- Includes Formed and Welded Steel Stand
- Both Tables Tilt
- Two Cast Iron Tables
- Safety Paddle Switch with Lock

Wiring Diagram



⚠ WARNING!
SHOCK HAZARD!
 Disconnect power before working on wiring.

NOTICE
 The motor wiring shown here is current at the time of printing, but it may not match your machine. Always use the wiring diagram inside the motor junction box.

COLOR KEY

BLACK	
WHITE	
GREEN	
RED	
BLUE	
GRAY	

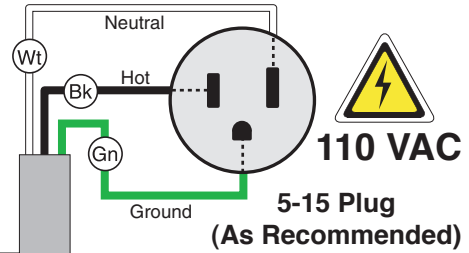
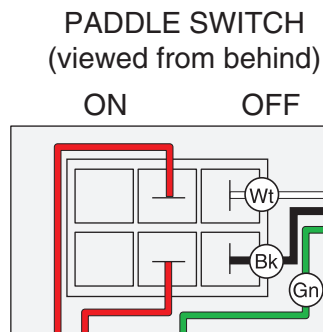

View this page in color at www.grizzly.com.

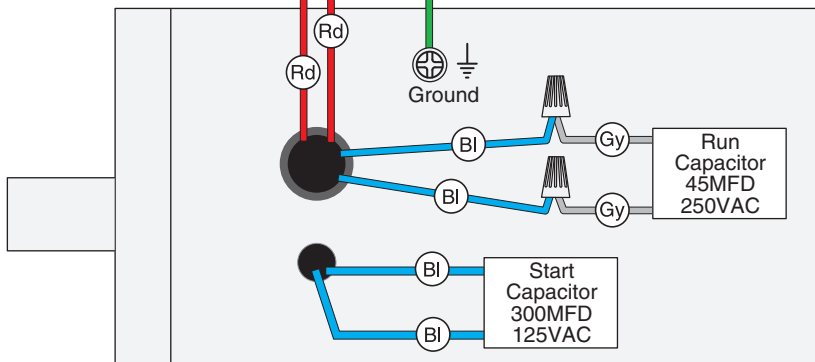

110V MOTOR

Frame Breakdown

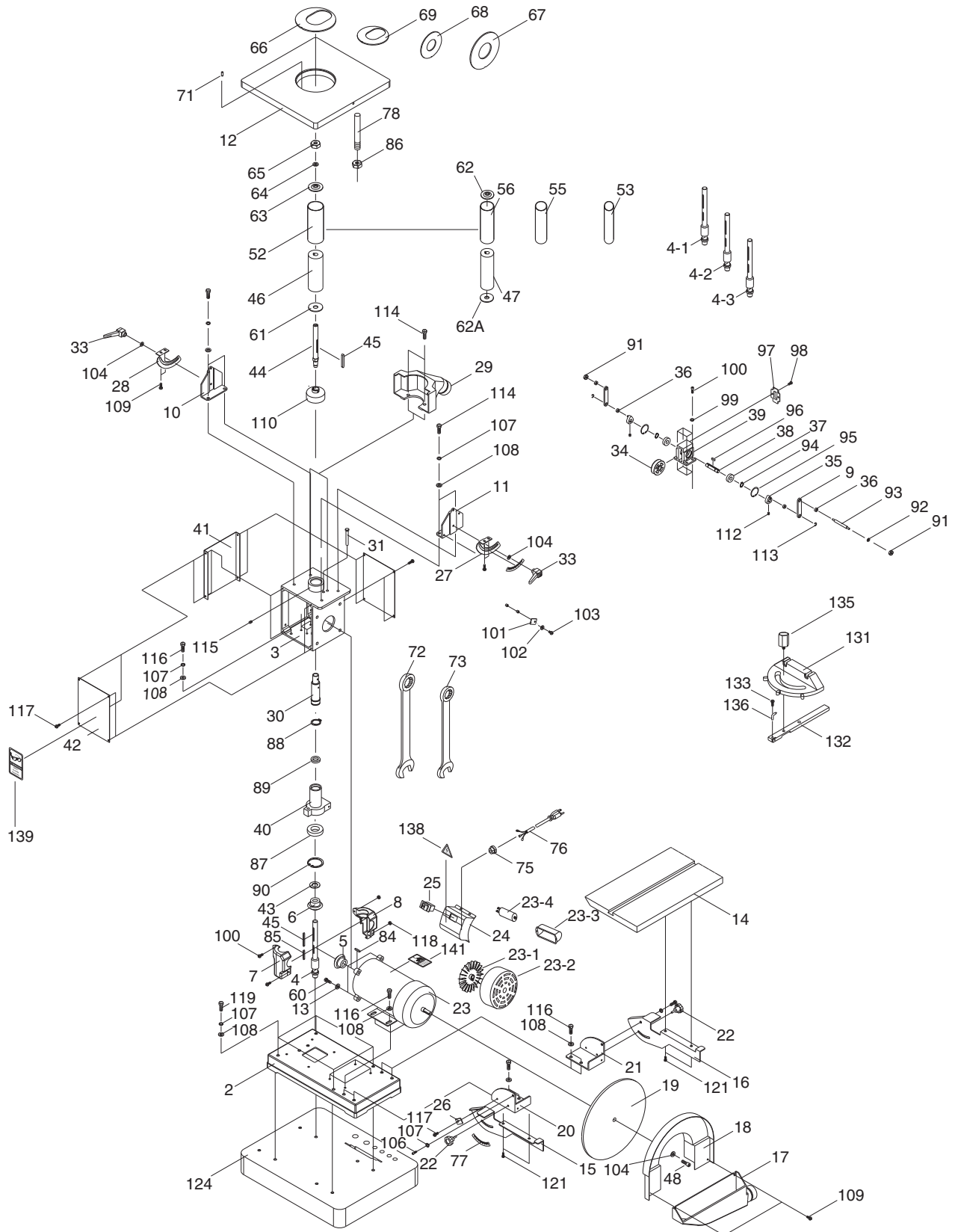

Frame Parts List

REF	PART #	DESCRIPTION
2	P0529002	BASE UPPER
3	P0529003	FRAME
4	P0529004	SPINDLE 2"
4-1	P0529004-1	SPINDLE 1-1/2"
4-2	P0529004-2	SPINDLE 5/8"
4-3	P0529004-3	SPINDLE 1/4"
5	P0529005	HELICAL BEVEL GEAR
6	P0529006	PU HELICAL BEVEL GEAR
7	P0529007	RIGHT OIL BOX
8	P0529008	LEFT OIL BOX
9	P0529009	CONNECTION ROD
10	P0529010	RIGHT BRACKET
11	P0529011	LEFT BRACKET
12	P0529012	WORKING TABLE
13	PW02	FLAT WASHER 3/8
14	P0529014	WORKING TABLE
15	P0529015	FRONT GRADUATED SCALE
16	P0529016	REAR GRADUATED SCALE
17	P0529017	DUST HOOD
18	P0529018	DISC GUARD
19	P0529019	DISC
20	P0529020	FRONT BRACKET
21	P0529021	REAR BRACKET
22	P0529022	HAND KNOB
23	P0529023	MOTOR 1 HP
23-1	P0529023-1	MOTOR FAN
23-2	P0529023-2	FAN COVER
23-3	P0529023-3	CAPACITOR COVER
23-4	P0529023-4	CAPACITOR
24	P0529024	SWITCH BOX
25	PSW06	PADDLE SWITCH WITH KEY
26	P0529026	INDICATOR
27	P0529027	RIGHT GRADUATED SCALE
28	P0529028	LEFT GRADUATED SCALE
29	P0529029	DUST HOOD
30	P0529030	SPINDLE
31	P0529031	GUIDE ROD
33	P0529033	HANDLE
34	P0529034	WORM GEAR
35	P0529035	CAM
36	P0529036	COPPER SLEEVE
37	P6001	BALL BEARING 6001ZZ
38	P0529038	WORM GEAR SHAFT
39	P0529039	WORM GEAR HOUSING
40	P0529040	CONNECTION PIECE
41	P0529041	SIDE COVER
42	P0529042	FRONT AND REAR COVER
43	P0529043	SPACER
44	P0529044	ARBOR 5/8
45	PK36M	KEY 5 X 5 X 50

REF	PART #	DESCRIPTION
46	P0529046	RUBBER PAD 2
47	P0529047	RUBBER PAD 1- 1/2
48	PSB05	CAP SCREW 1/4-20 X 3/4
52	P0529052	SANDING SLEEVE 2
53	P0529053	SANDING SLEEVE 1/4
55	P0529055	SANDING SLEEVE 5/8
56	P0529056	SANDING SLEEVE 1-1/2
60	PB32M	HEX BOLT M10-1.5 X 25
61	P0529061	LOWER FLANGE 2"
62	P0529062	UPPER FLANGE 1-1/2"
62A	P0529062A	LOWER FLANGE 1-1/2"
63	P0529063	UPPER FLANGE 2"
64	PW07	FLAT WASHER 5/16
65	PN35	HEX NUT 5/16-18 (LH)
66	P0529066	ELLIPTICAL TABLE INSERT 2"
67	P0529067	ROUND TABLE INSERT 2"
68	P0529068	ROUND TABLE INSERT 3/4"
69	P0529069	ELLIPTICAL TABLE INSERT 3/4"
71	PRP61M	ROLL PIN 3 X 12
72	PWR1417	WRENCH 14 X 17
73	PWR1214	COMBO WRENCH 12/14MM
75	P0529075	STRAIN RELIEF BUSHING
76	PWRCRD110L	POWER CORD
77	P0529077	GRADUATED SCALE
78	P0529078	POSITIONING ROD
84	PK20M	KEY 5 X 5 X 15
85	PK42M	KEY 6 X 6 X 30
86	PN08	HEX NUT 3/8-16
87	P6006	BALL BEARING 6006ZZ
88	PR19M	EXT RETAINING RING 28MM
89	P6804	BALL BEARING 6804ZZ
90	PR55M	INT RETAINING RING 60MM
91	PLN02M	LOCK NUT M5-.8
92	PW02M	WASHER 5MM
93	P0529093	CONNECTION SHAFT
94	PR03M	EXT RETAINING RING 12MM
95	PR20M	INT RETAINING RING 28MM
96	PK47M	KEY 4 X 4 X 15
97	P0529097	REAR OIL COVER
98	PS18	PHLP HD SCR 10-24 X 1/4
99	PLW03M	LOCK WASHER 6MM
100	PSB28M	CAP SCREW M6-1 X 15
101	P0529101	POINTER
102	PLW01M	LOCK WASHER 5MM
103	PS22M	PHLP HD SCR M5-.8 X 25
104	PW06	FLAT WASHER 1/4
106	PSB07	CAP SCREW 5/16-18 X 3/4
107	PLW01	LOCK WASHER 5/16
108	PW07	FLAT WASHER 5/16
109	PSB33M	CAP SCREW M5-.8 X 12

REF	PART #	DESCRIPTION
110	P0529110	COVER
112	PSS08M	SET SCREW M4-.7 X 5
113	PEC02M	E-CLIP 4MM
114	PB07M	HEX BOLT M8-1.25 X 25
115	PSS02M	SETSCREW M6-1 X 5
116	PB03	HEX BOLT 5/16-18 X 1
117	PS06	PHLP HD SCR 10-24 X 3/8
118	PN01M	HEX NUT M6-1
119	PB04	HEX BOLT 5/16-18 X 3
121	PB19	HEX BOLT 1/4-20 X 1/2

REF	PART #	DESCRIPTION
124	P0529124	STAND TOP
131	P0529131	MITER GAUGE BODY
132	P0529132	MITER GAUGE BAR
133	PS06	PHLP HD SCR 10-24 X 3/8
135	P0529135	MITER GAUGE KNOB
136	P0529136	POINTER
138	PLABEL-14	WARNING LABEL-ELECTRICITY
139	PLABEL-11	WARNING LABEL-GLASSES
141	PLABEL-26	WARNING LABEL-DISCONNECT

Cabinet Breakdown

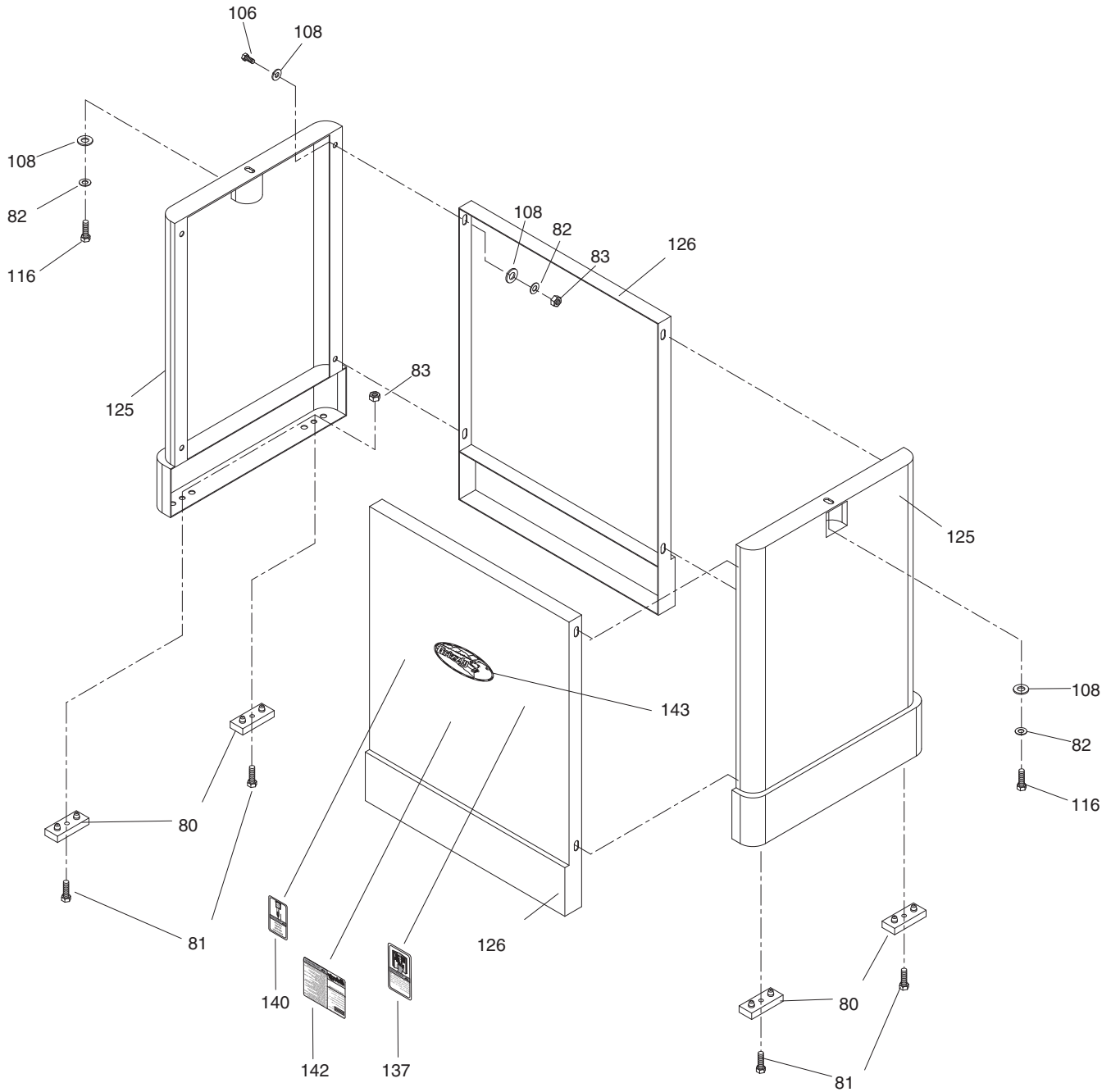

REF	PART #	DESCRIPTION
80	P0529080	PAD
81	PFH14	FLAT HD SCR 5/16-18 X 3/4
82	PLW01	LOCK WASHER 5/16
83	PN02	HEX NUT 5/16-18
106	PSB07	CAP SCREW 5/16-18 X 3/4
108	PW07	FLAT WASHER 5/16
116	PB03	HEX BOLT 5/16-18 X 1

REF	PART #	DESCRIPTION
125	P0529125	RIGHT OR LEFT PANEL
126	P0529126	FRONT OR REAR PANEL
137	PLABEL-12	WARNING LABEL-READ MANUAL
140	PLABEL-32	WARNING LABEL-DUST MASK
142	P0529142	WARNING LABEL-ID LABEL
143	G8588	GRIZZLY LOGO

Troubleshooting

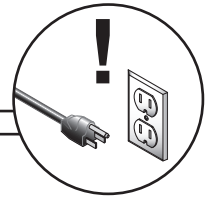

Motor & Electrical

Symptom	Possible Cause	Possible Solution
Motor will not start.	<ol style="list-style-type: none"> 1. Low voltage. 2. Open circuit in motor or loose connections. 	<ol style="list-style-type: none"> 1. Check power line for proper voltage. 2. Inspect all lead connections on motor for loose or open connections.
Motor will not start; fuses or circuit breakers blow.	<ol style="list-style-type: none"> 1. Short circuit in line cord or plug. 2. Short circuit in motor or loose connections. 3. Incorrect fuses or circuit breakers in power line. 	<ol style="list-style-type: none"> 1. Inspect cord or plug for damaged insulation and shorted wires. 2. Inspect all connections on motor for loose or shorted terminals or worn insulation. 3. Install correct fuses or circuit breakers.
Motor overheats.	<ol style="list-style-type: none"> 1. Motor overloaded. 2. Incorrect usage of machine. 3. Air circulation through the motor restricted. 	<ol style="list-style-type: none"> 1. Reduce load on motor. 2. Reduce the applied load on the machine. 3. Clean out motor to provide normal air circulation.
Motor stalls (resulting in blown fuses or tripped circuit).	<ol style="list-style-type: none"> 1. Short circuit in motor or loose connections. 2. Low voltage. 3. Incorrect fuses or circuit breakers in power line. 4. Motor overloaded. 	<ol style="list-style-type: none"> 1. Inspect connections on motor for loose or shorted terminals or worn insulation. 2. Correct the low voltage conditions. 3. Install correct fuses or circuit breakers. 4. Reduce load on motor.

Machine Operation

Symptom	Possible Cause	Possible Solution
Grains easily rub off the sleeve or disc.	<ol style="list-style-type: none"> 1. Sanding sleeve/disc has been stored in an incorrect environment. 2. Sanding sleeve/disc has been smashed or folded. 	<ol style="list-style-type: none"> 1. Store sanding sleeve/disc away from extremely hot or dry temperatures. 2. Store sanding sleeve/disc flat not bent or folded.
Deep sanding grooves or scars in workpiece.	<ol style="list-style-type: none"> 1. Sanding sleeve/disc grit is too coarse for the desired finish. 2. Workpiece sanded across the grain. 3. Too much sanding force on workpiece. 4. Workpiece held still against the sleeve/disc. 	<ol style="list-style-type: none"> 1. Use a finer grit sanding sleeve/disc. 2. Sand with the grain. 3. Reduce pressure on workpiece while sanding. 4. Keep workpiece moving while sanding on the sleeve/disc.
Sanding surface clogs quickly or burns.	<ol style="list-style-type: none"> 1. Too much pressure against sleeve/disc. 2. Sanding softwood. 	<ol style="list-style-type: none"> 1. Reduce pressure on workpiece while sanding. 2. Use different stock. Or, accept the characteristics of the stock and plan on cleaning/replacing sleeves frequently.
Glazed sanding surfaces.	<ol style="list-style-type: none"> 1. Sanding wet stock. 2. Sanding stock with high residue. 	<ol style="list-style-type: none"> 1. Dry stock properly before sanding. 2. Use different stock. Or, accept the characteristics of the stock and plan on cleaning/replacing sleeves/discs frequently.
Burn marks on workpiece.	<ol style="list-style-type: none"> 1. Using too fine of sanding grit. 2. Using too much pressure. 3. Work held still for too long. 	<ol style="list-style-type: none"> 1. Use a coarser grit sanding sleeve/disc. 2. Reduce pressure on workpiece while sanding. 3. Do not keep workpiece in one place for too long.

Machine Operation Continued

Symptom	Possible Cause	Possible Solution
Machine slows when operating.	<ol style="list-style-type: none"> 1. Applying too much pressure to workpiece. 2. Undersized circuit or using ext cord. 	<ol style="list-style-type: none"> 1. Sand with less pressure—let the movement of the sleeve/disc do the work. 2. Make sure circuit wires are proper gauge & don't use ext cords!
Machine vibrates excessively.	<ol style="list-style-type: none"> 1. Stand not stable on floor. 2. Incorrect motor mounting. 3. Incorrect sanding sleeve tension. 4. Broken/defective sanding sleeve/disc. 	<ol style="list-style-type: none"> 1. Secure stand to floor, reposition to level surface, or shim stand. 2. Check/adjust motor mounting. 3. Make sure tension lever is in tensioning position. Follow sleeve tensioning instructions in this manual. 4. Replace sanding sleeve/disc.
Workpiece frequently gets pulled out of your hand.	<ol style="list-style-type: none"> 1. Not supporting the workpiece against the stop. 2. Starting the workpiece on a leading corner. 	<ol style="list-style-type: none"> 1. Use back stop to support workpiece. 2. Start workpiece on a trailing corner.



WARRANTY CARD

Name _____
 Street _____
 City _____ State _____ Zip _____
 Phone # _____ Email _____
 Model # _____ Order # _____ Serial # _____

The following information is given on a voluntary basis. It will be used for marketing purposes to help us develop better products and services. **Of course, all information is strictly confidential.**

- How did you learn about us?

<input type="checkbox"/> Advertisement	<input type="checkbox"/> Friend	<input type="checkbox"/> Catalog
<input type="checkbox"/> Card Deck	<input type="checkbox"/> Website	<input type="checkbox"/> Other:
- Which of the following magazines do you subscribe to?

<input type="checkbox"/> Cabinetmaker & FDM	<input type="checkbox"/> Popular Science	<input type="checkbox"/> Wooden Boat
<input type="checkbox"/> Family Handyman	<input type="checkbox"/> Popular Woodworking	<input type="checkbox"/> Woodshop News
<input type="checkbox"/> Hand Loader	<input type="checkbox"/> Precision Shooter	<input type="checkbox"/> Woodsmith
<input type="checkbox"/> Handy	<input type="checkbox"/> Projects in Metal	<input type="checkbox"/> Woodwork
<input type="checkbox"/> Home Shop Machinist	<input type="checkbox"/> RC Modeler	<input type="checkbox"/> Woodworker West
<input type="checkbox"/> Journal of Light Cont.	<input type="checkbox"/> Rifle	<input type="checkbox"/> Woodworker's Journal
<input type="checkbox"/> Live Steam	<input type="checkbox"/> Shop Notes	<input type="checkbox"/> Other:
<input type="checkbox"/> Model Airplane News	<input type="checkbox"/> Shotgun News	
<input type="checkbox"/> Old House Journal	<input type="checkbox"/> Today's Homeowner	
<input type="checkbox"/> Popular Mechanics	<input type="checkbox"/> Wood	
- What is your annual household income?

<input type="checkbox"/> \$20,000-\$29,000	<input type="checkbox"/> \$30,000-\$39,000	<input type="checkbox"/> \$40,000-\$49,000
<input type="checkbox"/> \$50,000-\$59,000	<input type="checkbox"/> \$60,000-\$69,000	<input type="checkbox"/> \$70,000+
- What is your age group?

<input type="checkbox"/> 20-29	<input type="checkbox"/> 30-39	<input type="checkbox"/> 40-49
<input type="checkbox"/> 50-59	<input type="checkbox"/> 60-69	<input type="checkbox"/> 70+
- How long have you been a woodworker/metalworker?

<input type="checkbox"/> 0-2 Years	<input type="checkbox"/> 2-8 Years	<input type="checkbox"/> 8-20 Years	<input type="checkbox"/> 20+ Years
------------------------------------	------------------------------------	-------------------------------------	------------------------------------
- How many of your machines or tools are Grizzly?

<input type="checkbox"/> 0-2	<input type="checkbox"/> 3-5	<input type="checkbox"/> 6-9	<input type="checkbox"/> 10+
------------------------------	------------------------------	------------------------------	------------------------------
- Do you think your machine represents a good value? Yes No
- Would you recommend Grizzly Industrial to a friend? Yes No
- Would you allow us to use your name as a reference for Grizzly customers in your area?
Note: We never use names more than 3 times. Yes No

10. Comments: _____

CUT ALONG DOTTED LINE

FOLD ALONG DOTTED LINE



Place
Stamp
Here



GRIZZLY INDUSTRIAL, INC.
P.O. BOX 2069
BELLINGHAM, WA 98227-2069



FOLD ALONG DOTTED LINE

Send a Grizzly Catalog to a friend:

Name _____

Street _____

City _____ State _____ Zip _____

TAPE ALONG EDGES--PLEASE DO NOT STAPLE

WARRANTY AND RETURNS

Grizzly Industrial, Inc. warrants every product it sells for a period of **1 year** to the original purchaser from the date of purchase. This warranty does not apply to defects due directly or indirectly to misuse, abuse, negligence, accidents, repairs or alterations or lack of maintenance. This is Grizzly's sole written warranty and any and all warranties that may be implied by law, including any merchantability or fitness, for any particular purpose, are hereby limited to the duration of this written warranty. We do not warrant or represent that the merchandise complies with the provisions of any law or acts unless the manufacturer so warrants. In no event shall Grizzly's liability under this warranty exceed the purchase price paid for the product and any legal actions brought against Grizzly shall be tried in the State of Washington, County of Whatcom.

We shall in no event be liable for death, injuries to persons or property or for incidental, contingent, special, or consequential damages arising from the use of our products.

To take advantage of this warranty, contact us by mail or phone and give us all the details. We will then issue you a "Return Number," which must be clearly posted on the outside as well as the inside of the carton. We will not accept any item back without this number. Proof of purchase must accompany the merchandise.

The manufacturers reserve the right to change specifications at any time because they constantly strive to achieve better quality equipment. We make every effort to ensure that our products meet high quality and durability standards and we hope you never need to use this warranty.

Please feel free to write or call us if you have any questions about the machine or the manual.

Thank you again for your business and continued support. We hope to serve you again soon.

grizzly.com[®]
TOOL WEBSITE

Buy Direct and Save with Grizzly[®] – Trusted, Proven and a Great Value!
~Since 1983~

*Visit Our Website Today For
Current Specials!*

**ORDER
24 HOURS A DAY!
1-800-523-4777**

